

# WINNERS ONLY®

## ASSEMBLY INSTRUCTIONS

PROD. NO : C1-TO450S - -P

Thank you for purchasing this quality product. Please read the instructions thoroughly before unpacking the assembly parts.

Caution: sharp exposed staple tips can cause injury, therefore for your protection, please remove any exposed staples used in packing.

Please keep all hardware parts out of the reach of children.

1. We recommend that you should assemble this product with the assistance of another person; this will make the assembly easier, and will help to prevent personal injury and to insure parts are not damaged during the assembly process.

2. Before beginning, please check the packing materials carefully for small parts which may have come loose inside the carton during shipping. Please do not discard any packing material until all parts have been located. If any parts are missing, please contact your dealer for prompt replacement.





3. To prevent damage to your floor or carpet, please check the bottom of each piece of furniture for stain residues and rough surfaces and also check for staples or nails left after removing the packing materials. The manufacturer will not be held responsible if preventive steps are not taken prior to installation.

4. Please do not over tighten screws or bolts. During normal use everyday, screws, bolts, nuts and wooden plugs may loosen up. They should be periodically inspected and re-tightened to prevent damage to the furniture and (or) personal property or cause injury. Always check to be sure all hardware on this list and the below mentioned components are attached to the furniture properly and kept tightened.



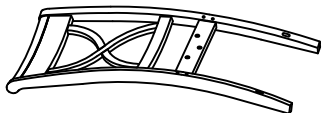

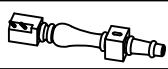
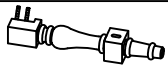
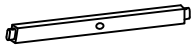



5. Please lay all parts and hardware on a non abrasive surface such as a carpet, and follow the assembly

This product will take 15-20 minutes to assemble

### Components List :

NO	DESCRIPTION	SKETCH	QTY
A	Back Rest		1pc
B	Wooden Seat		1pc
C	Front Leg (Left)		1pc
D	Front Leg (Right)		1pc
E	Side Stretcher (Left)		1pc
F	Side Stretcher (Right)		1pc
G	Center Stretcher		1pc

### Hardware List :

NO	DESCRIPTION	SIZE	SKETCH	QTY
1	Allen Key	58x23x4 mm		1pc
2	Short Bolt	1/4" x38 mm		3pcs
3	Long Bolt	1/4" x85 mm		4pcs
4	Spring Washer	5/16" x Ø12		11pcs
5	Flat Washer	5/16" x Ø19		11pcs
6	Wrench	12x75 mm		1pc
7	Hex-Nut	5/16"		4pcs
8	Wood Screw	Ø8 x 50 mm		6pcs

Screw driver is require for assembly (not included)

#### Reminders

1. Use only the hardware supplied.
2. Once the chair is finished, level and tighten all the bolts.
3. Do not over-tighten bolts.
4. This item may require periodic tightening.

#### NOTE :

1. Hardware pack is located underneath the Wooden Seat (B).
2. Two or more people are needed for assembly. Please keep all hardware parts out of the reach of children.

TIP: store the Allen key and or Wrench used in assembly in this product's drawer or use masking or painter's tape to affix it to the underside of the product. This will make it easier to find if you want to periodically tighten bolts or disassemble the product.

# WINNERS ONLY®

## ASSEMBLY INSTRUCTIONS

PROD. NO : C1-TO450S - -P

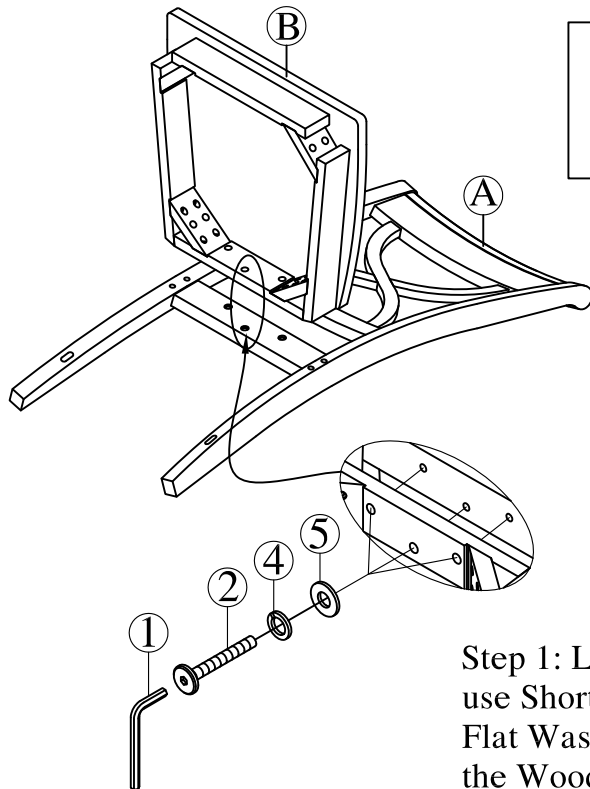

Fig.1

Step 1: Lay the Backrest (A) on a flat soft surface, use Short Bolt (2), Spring Washer (4), Flat Washer (5) and Allen Key (1) to attached the Wooden Seat (B) to Backrest (A) as shown in Fig. 1.

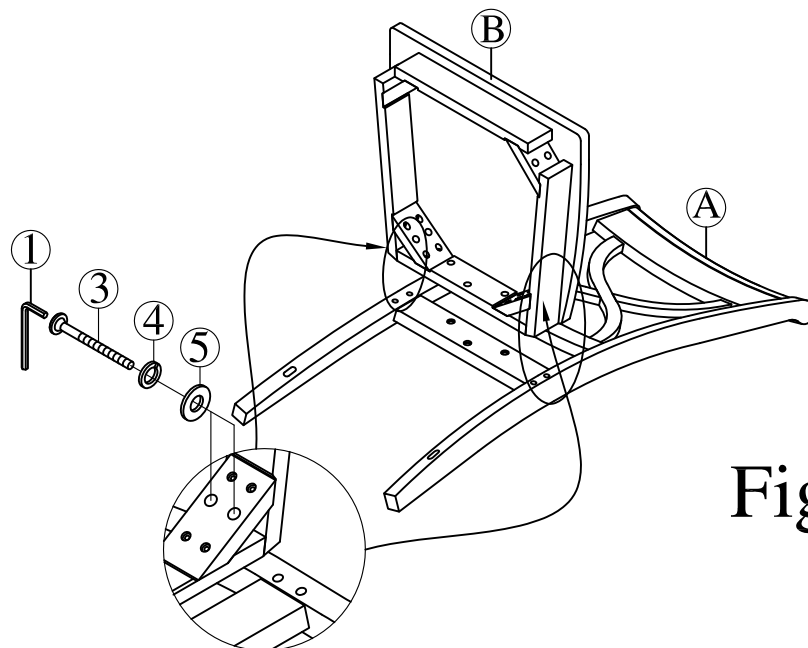

Fig.2

Step 2 : Use Long Bolt (3), Spring Washer (4) Flat Washer (5) and Allen Key (1) to attached the Wooden Seat (B) to Chair Backrest (A) as shown in Fig. 2 .  
Do not fully tighten bolts yet.

# WINNERS ONLY®

## ASSEMBLY INSTRUCTIONS

PROD. NO : C1-TO450S - -P

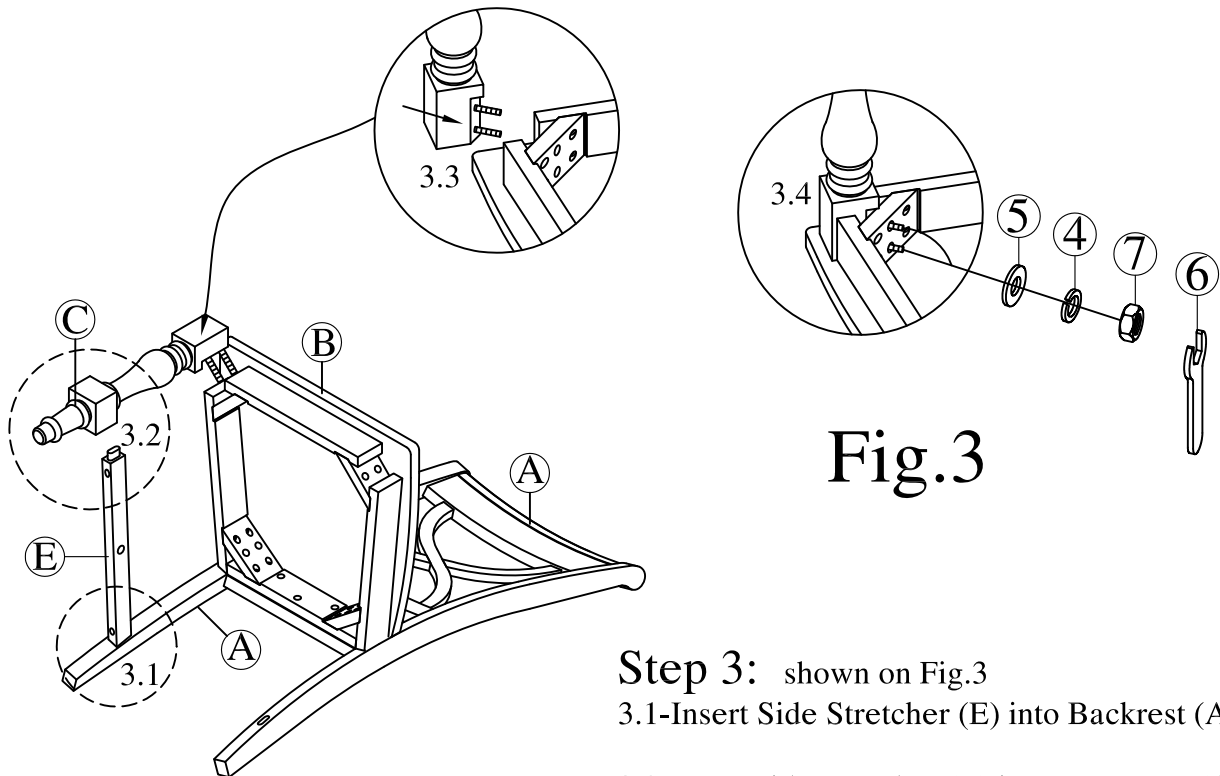

Fig.3

**Step 3:** shown on Fig.3

3.1-Insert Side Stretcher (E) into Backrest (A).

3.2-Insert side stretcher (E) into Front Leg (C).

3.3- Insert Front leg (C) into Wooden Seat (B).

3.4- Use Hex-Nut (7), Spring Washer (4), Flat Washer (5) and tighten with Wrench (6) to attach Front Leg (C) to Wooden Seat (B).

**Do Not Fully Tighten Bolts Yet**

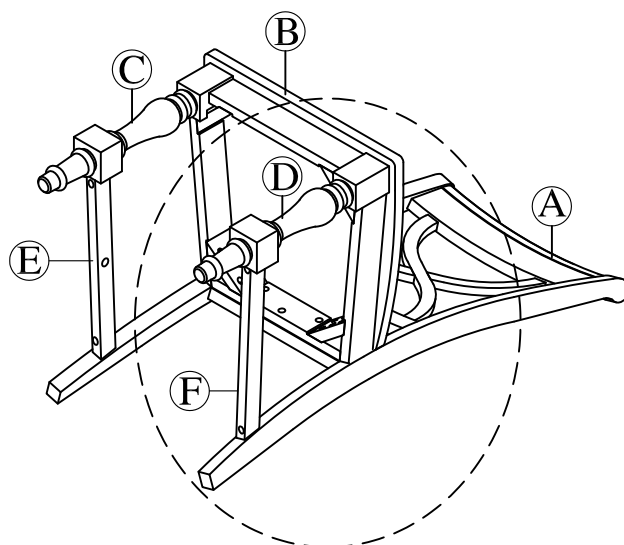

Fig.4

**Step 4.**

Repeat step 3 to attach the remaining Side Stretcher (F) and Front Leg (D) to Wooden Seat (B) as shown on Fig.4 .

# WINNERS ONLY®

## ASSEMBLY INSTRUCTIONS

PROD. NO : C1-TO450S - -P

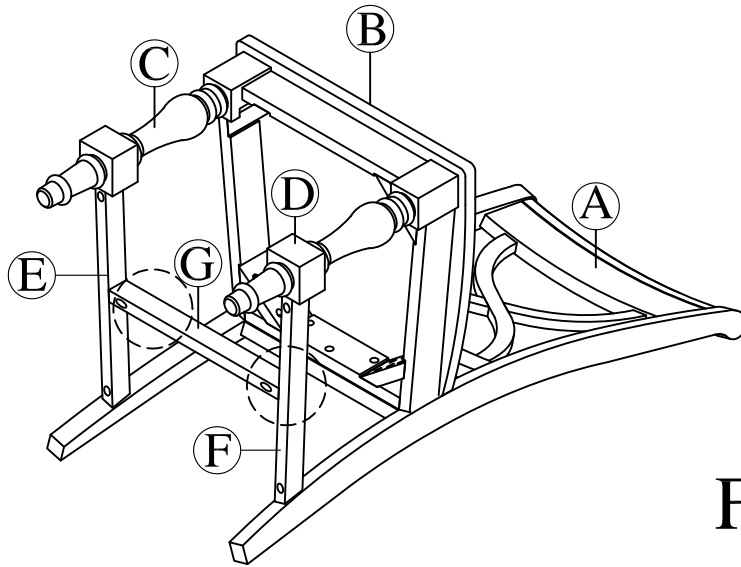

Fig.5

Step 5:

Insert Center Stretcher (G) Between side stretchers (E & F)  
as shown in Fig 5.

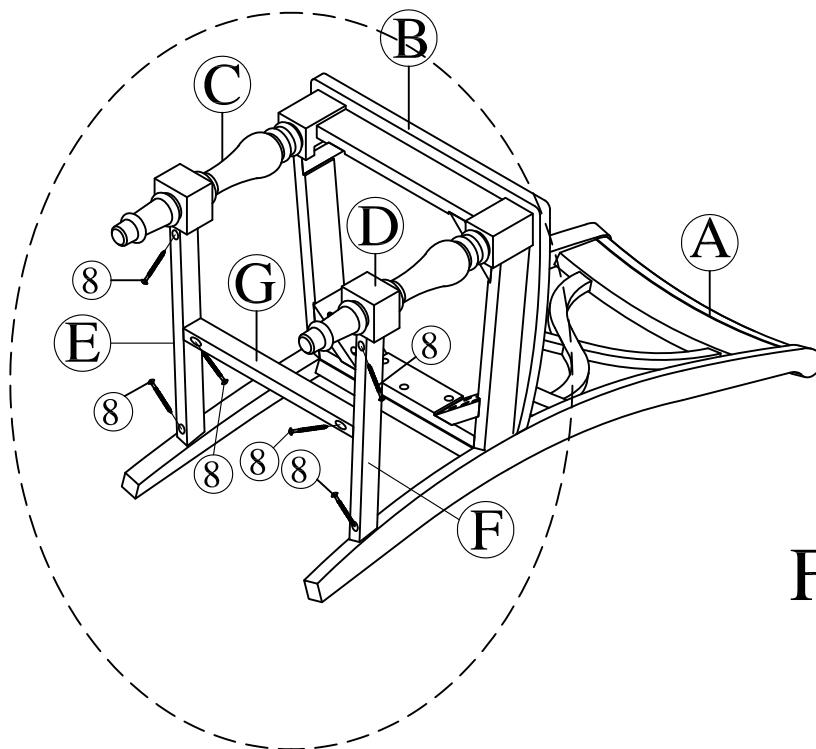

Fig.6

Step 6 : Insert Wood Screw (8) to fasten  
All stretchers (E, F, G) as shown on Fig. 6

# WINNERS ONLY®

## ASSEMBLY INSTRUCTIONS

PROD. NO : C1-TO450S - -P

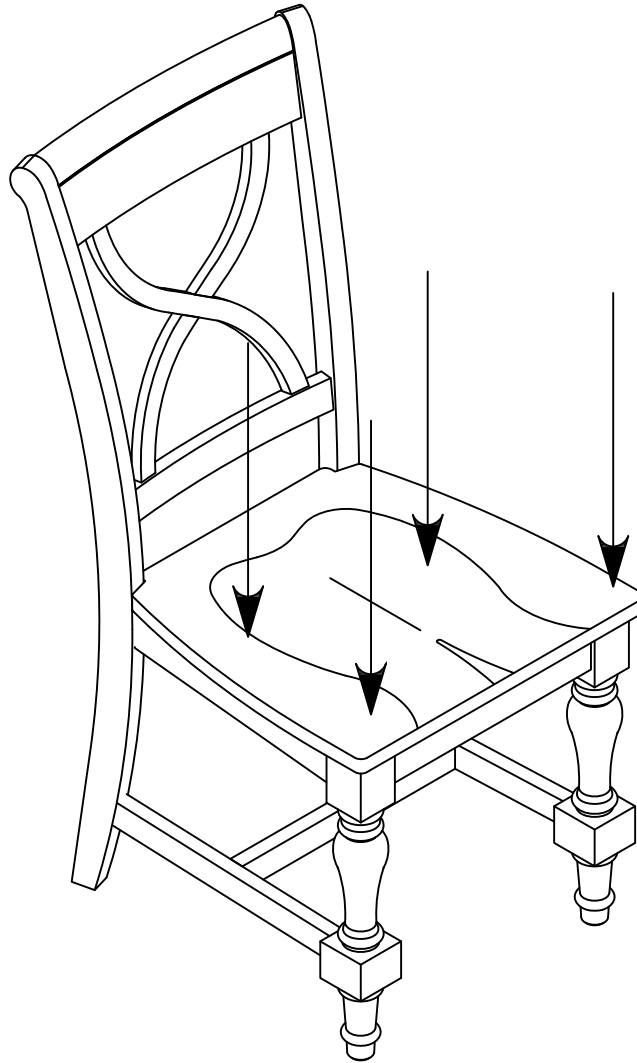

Fig.7

Step 7: Place the loosely assembled chair on a hard flat surface and apply gentle downward pressure on the seat. As shown on Fig.7. Once the chair is balanced and leveled, fully tighten all bolts.

### Assembly is now Complete