

WINNERS ONLY®

ASSEMBLY INSTRUCTIONS

PROD. NO : C1-SN45424- -X

C1-SN45424- -G

Thank you for purchasing this quality product . Be sure to check all packaging material carefully for small parts that may have come loose inside the carton during shipment .

"Hardware is attached underneath the seat bottom"

Components List :

NO	DESCRIPTION	SKETCH	QTY
A	Back Frame		1pc
B	Seat Frame with Cushion		1pc
C	Front Leg		2pcs
D	Side Stretcher (Left)		1pc
E	Side Stretcher (Right)		1pc
F	Front Stretcher		1pc
G	Velcro		1pc
H	Plastic Glide		4pcs

STEP 1

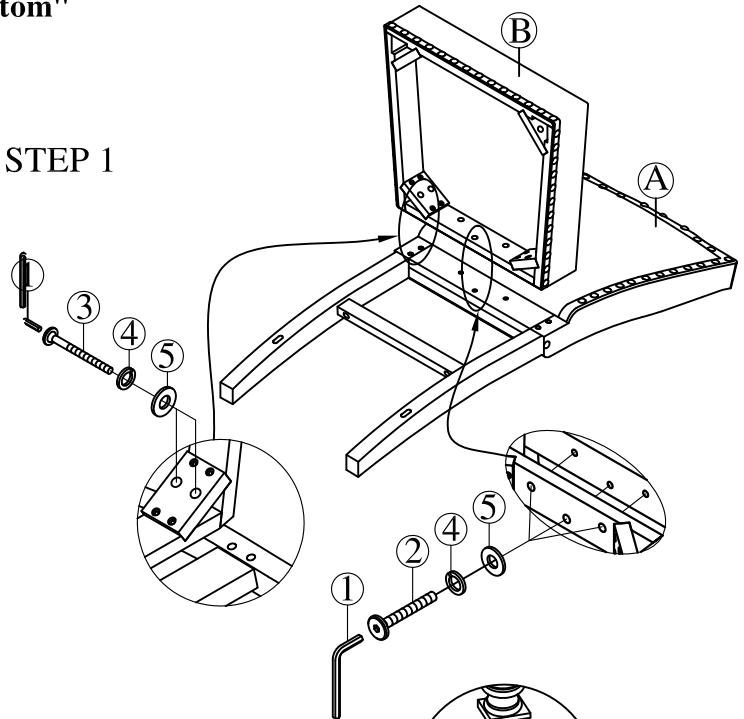

STEP 2

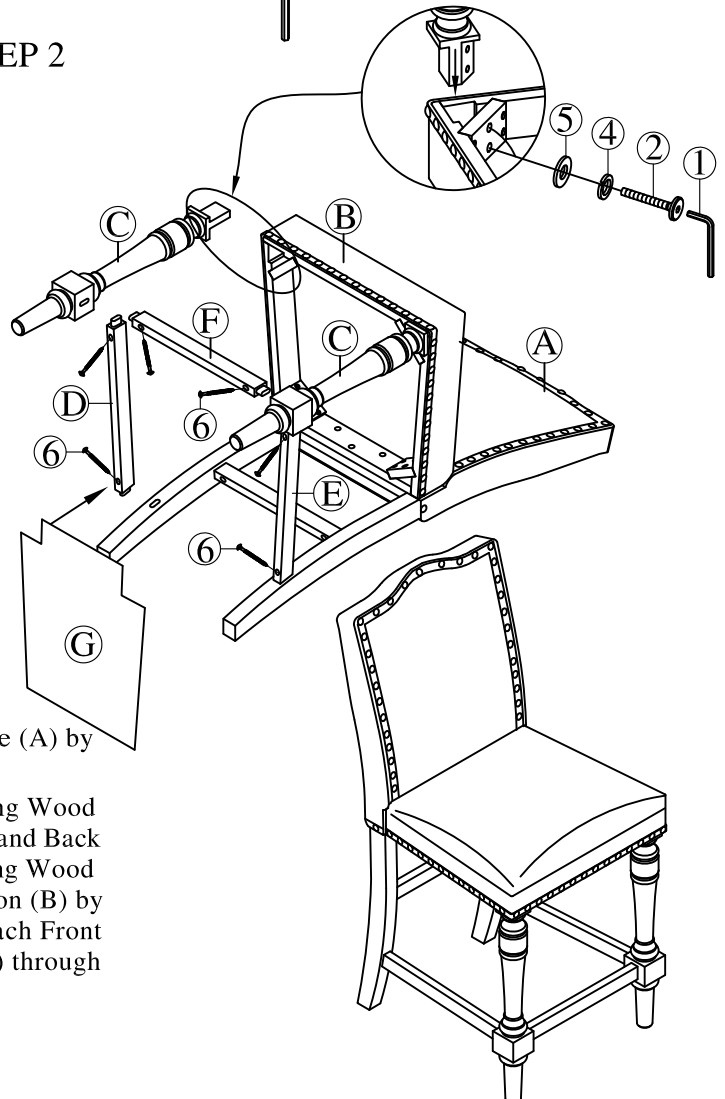

Hardware List :

NO	DESCRIPTION	SIZE	SKETCH	QTY
1	Allen Key	58x23x4 mm		1pc
2	Short Bolt	1/4" x45 mm		7pcs
3	Long Bolt	1/4" x85 mm		4pcs
4	Spring Washer	5/16" x Ø12		11pcs
5	Flat Washer	5/16" x Ø19		11pcs
6	Wood Screw	Ø8 x 50 mm		6pcs

Reminders

1. Use only the hardware supplied.
2. Once the chair is finished, level and tighten all the bolts.
3. Do not over-tighten bolts.
4. This item may require periodic tightening.

NOTE :

1. Hardware pack is located underneath the Seat Frame with Cushion(B).
2. Two or more people are needed for assembly. Please keep all hardware parts out of the reach of children.

Step1: Attach the Seat Frame with Cushion (B) to Back Frame (A) by using Flat Washer (5), Spring Washer (4) and Bolt (2&3).

Step2: Attach Side Stretcher (D & E) to Back Frame (A) using Wood Screws (6) through pre-drilled holes of Side Stretcher (D & E) and Back Frame (A). Assemble Front Stretcher (F) to Front Legs (C) using Wood Screw (6). Attach the Front Leg (C) to Seat Frame with Cushion (B) by using Flat Washers (5), Spring Washers (4) and Bolt (2). Attach Front Legs (C) to the Side Stretcher (D&E) using Wood Screws (6) through pre-drilled holes on the Side Stretcher (D&E).

Step3: Attach the Velcro (G) to Seat Frame with Cushion(B)

Assembly is now complete
Thank you for choosing this product.

MADE IN VIETNAM