

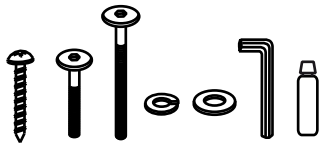



# Assembly Instructions

C1-DF10124- -G  
LADDERBACK BARSTOOL

## PARTS LIST

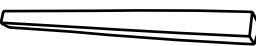
PART NO	FIGURE	DESCRIPTION	Q'TY
C1-DF10124--G-01		Hardware Bag	1 Pce
C1-DF10124--G-02		Chair Back	1 Pce
C1-DF10124--G-03		Cushion Seat	1 Pce
C1-DF10124--G-05		Front Leg (Right)	1 Pce
C1-DF10124--G-06		Front Leg (Left)	1 Pce
C1-DF10124--G-07		Side Stretcher (Right / Left)	2 Pcs
C1-DF10124--G-10		Front Stretcher	1 Pce

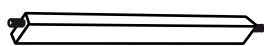
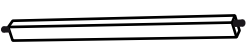
**IMPORTANT NOTE :** Please keep all hardware parts out of the reach of children.

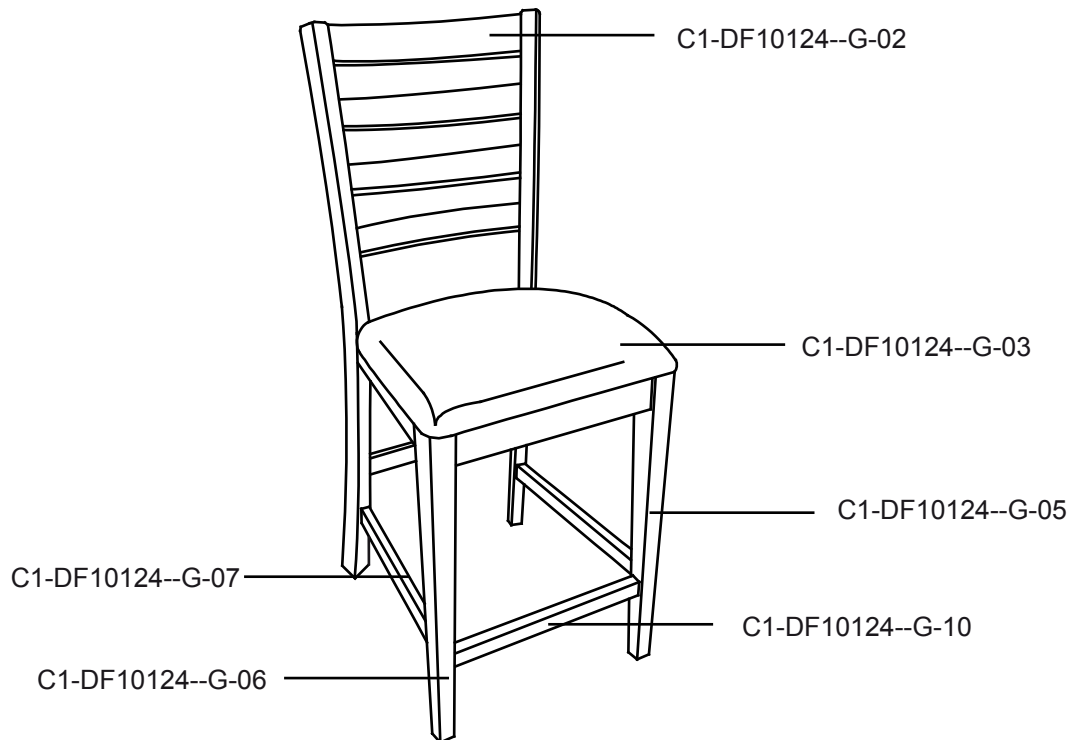

# Assembly Instructions

C1-DF10124- -G

## LADDERBACK BARSTOOL

### Reminders :







Two people are needed for assembly.

Use only hardware supplied.

Do not over tighten bolts.

This item may require periodic tightening.

### HARDWARE PARTS :

						
Pan Head Screw 6 pcs	(Short) JCBC Bolt 2 pcs	(Long) JCBC Bolt 8 pcs	Lock Washer 10 pcs	Flat Washer 10 pcs	Allen Key 1 pce	Glue 1 pce

### ASSEMBLY:

- Position the chair back on a soft surface such as a carpet. Place the box system assembly (Cushion is pre-attached to the seat frame in assembly) on to the middle rail of the chair back with the dowel fully inserted into the pre-drilled hole.
  - Insert **JCBC Bolt (Long)** through a **Lock Washer** and a **Flat Washer** into the pre-drilled holes on the apron frame at rear corners.
  - Insert the **JCBC Bolt (Short)** through a **Lock Washer** and a **Flat Washer** into the pre-drilled holes on the apron frame at rear rail.
- Apply **Glue** to all the pre-drilled holes before attaching all stretchers. Insert each side stretcher into pre-drilled holes on both of the rear legs, make sure that screw holes on the stretcher are facing down. Insert the front stretcher into the pre-drilled holes on the front legs. Place the assembled front legs to corner block of the frame, and insert side stretcher into the legs.
  - Insert the **JCBC Bolt (Long)** through a **Lock Washer**, a **Flat Washer** and the pre-drilled holes of corner block into the pre-drilled holes on the front leg, tighten the **JCBC Bolt** with **Allen Key** provided. But do not fully tighten the bolts yet.
  - Insert **Pan Head Screw** into front stretcher and side stretcher through the pre-drilled holes, tighten with screw driver. (Not Provided)

#### STEP 1

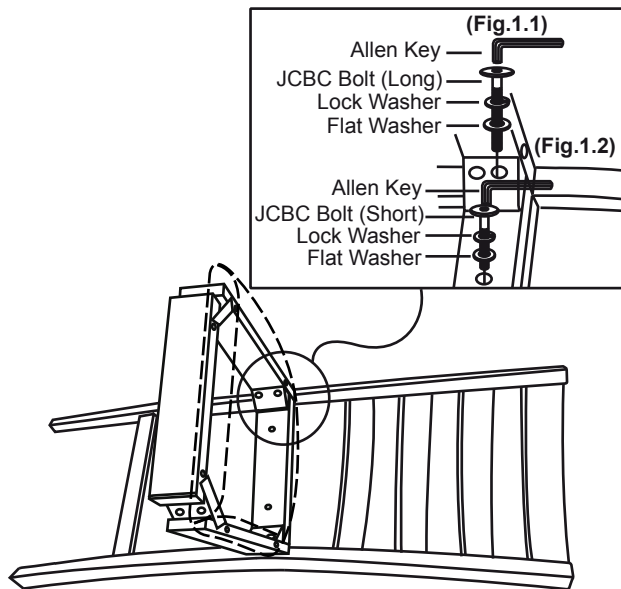

#### STEP 2

Assemble front leg as shown.

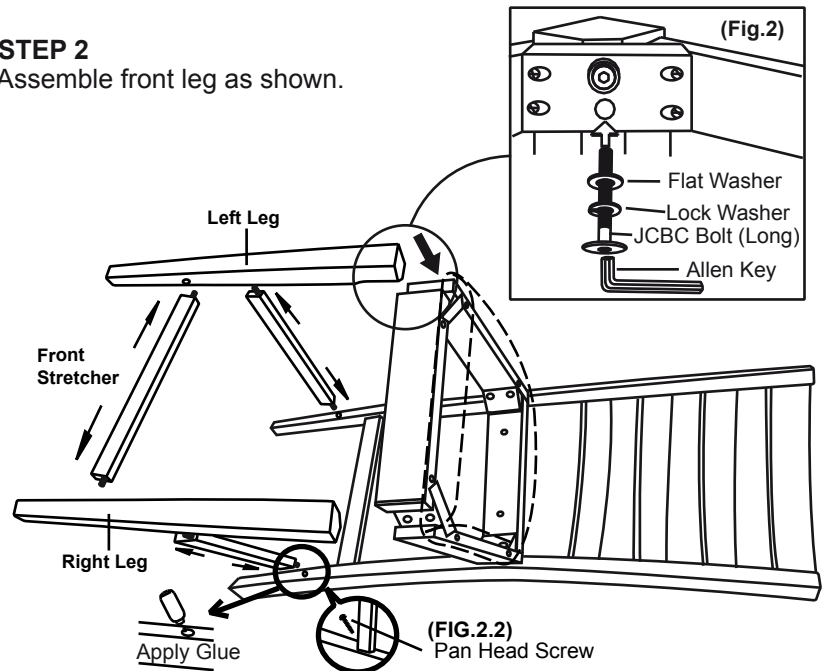

#### STEP 3

Turn the chair upright. Check its balance and tighten all screws and bolts to complete the assembly.

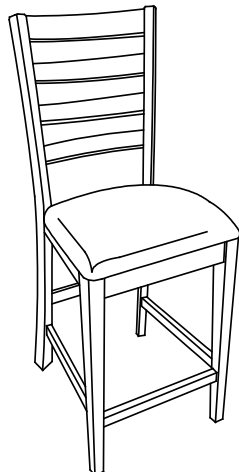

#### IMPORTANT NOTE :

~ Please keep all hardware out of the reach of children.

#### CARE INSTRUCTION

~ Be sure to use the same type of polish consistently. Your furniture will appear cloudy or streaky if oil based or wax based polishes are interchanged.  
~ Spray your furniture surface evenly. Wipe in a circular motion with a soft clean cloth.