

STUDIO 23" END TABLE

ASSEMBLY INSTRUCTION

Pg.1/2

Thank you for purchasing this quality product. Be sure to check all packing material carefully for small parts that may come loose inside the carton box during shipment.

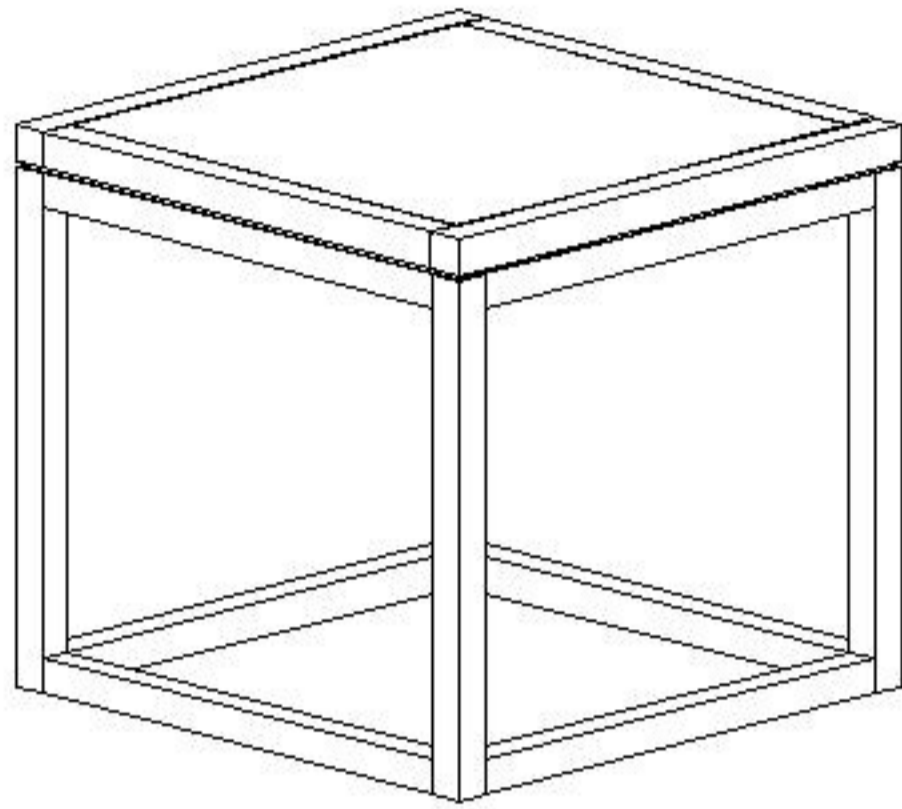

IMPORTANT

Please go through this assembly instruction before starting assembly. Kindly follow the sequence listed to assure fast, easy and correct assembly.

CARE & MAINTENANCE

Wipe clean with soft cloth and furniture polish.

MADE IN MALAYSIA

PARTS LIST

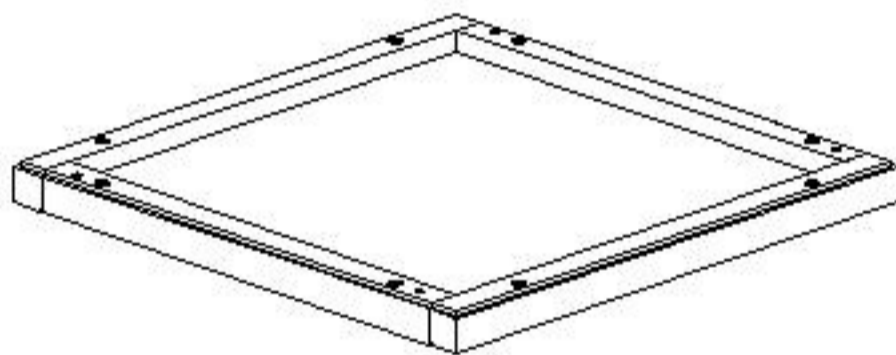

(A)
Table Top - 1 pc

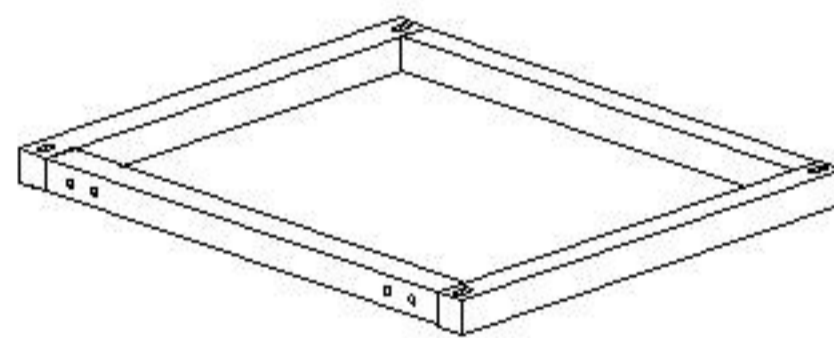

(B)
Side Panel - 2 pcs

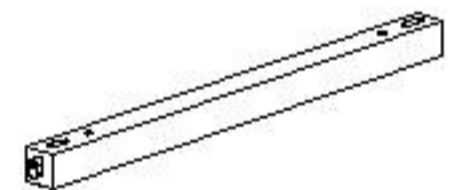

(C)
Top Rail - 2 pcs

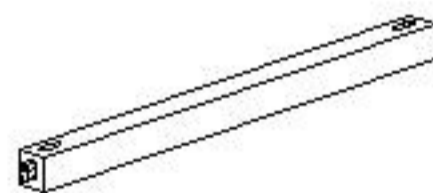

(D)
Bottom Rail - 2 pcs

HARDWARE LIST



(1) Wooden Dowel - 4 pcs

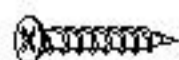

(2) M4x38mm Chipboard
Screw - 8 pcs



(3) M6x40mm JCBC
Screw - 8 pcs



(4) 4mm Hex Wrench - 1 pc

Note: EXTRA hardware are included

STUDIO 23" END TABLE

ASSEMBLY INSTRUCTION

Pg.2/2

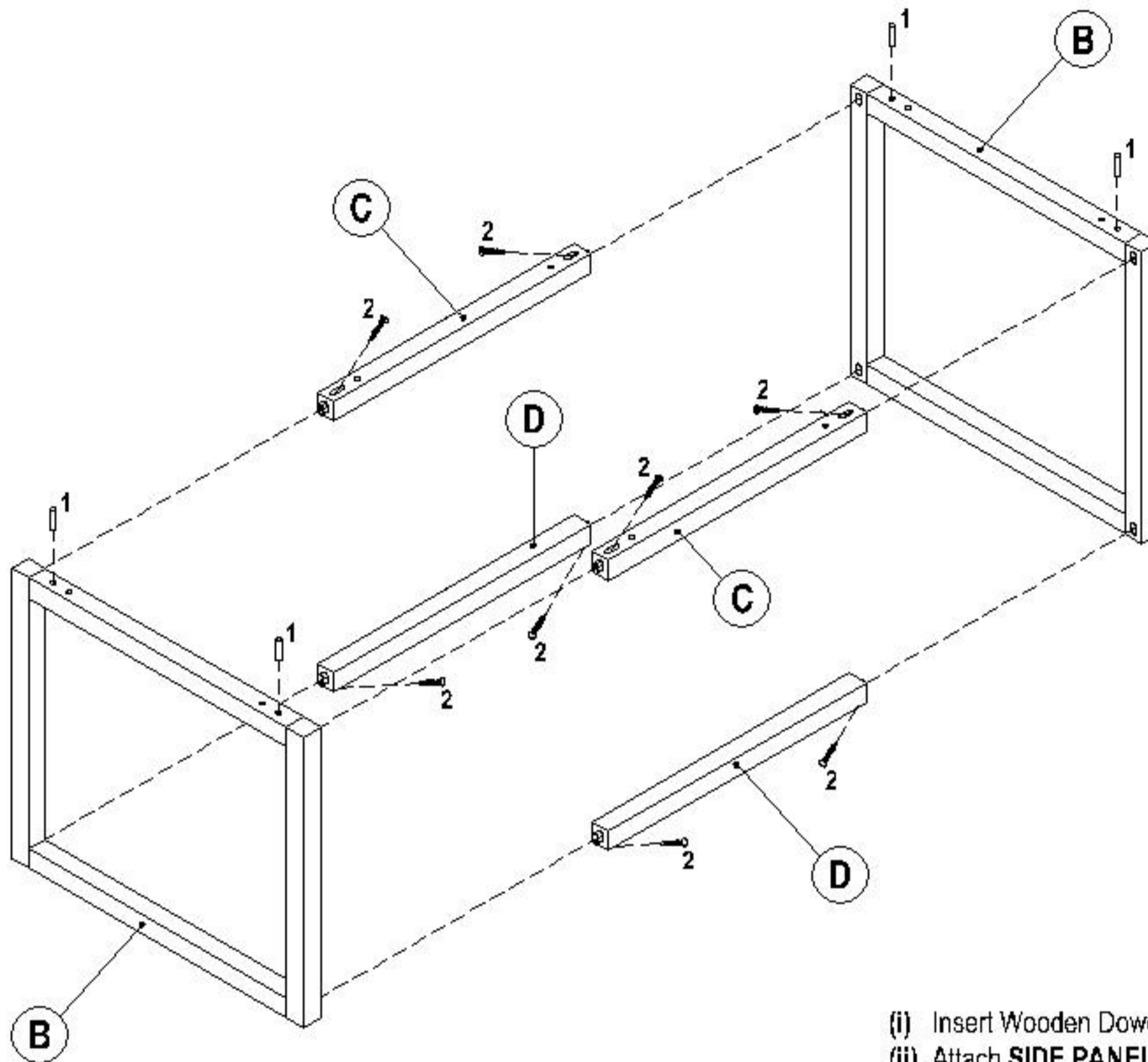

1

- (i) Insert Wooden Dowel (1) into holes at top of **SIDE PANEL (B)**.
- (ii) Attach **SIDE PANEL (B)** to **TOP RAIL (C)** & **BOTTOM RAIL (D)**.
- (iii) Tighten Chipboard Screw (2) to **TOP RAIL (C)** & **BOTTOM RAIL (D)** using Philips Head Screwdriver.

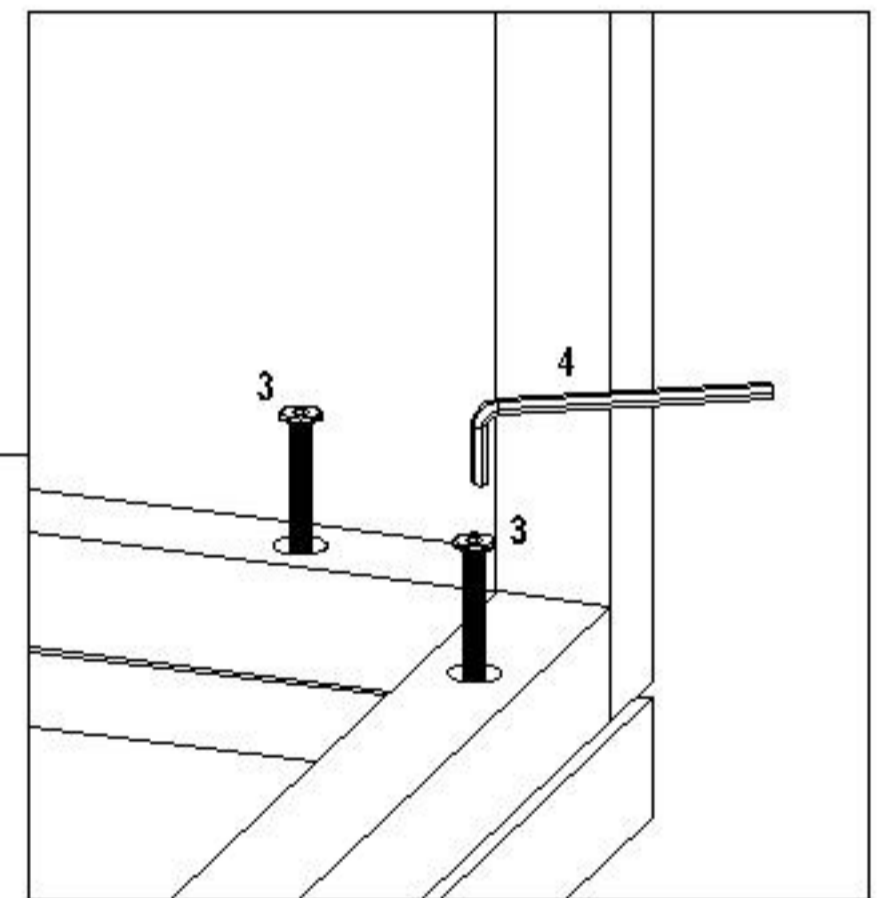
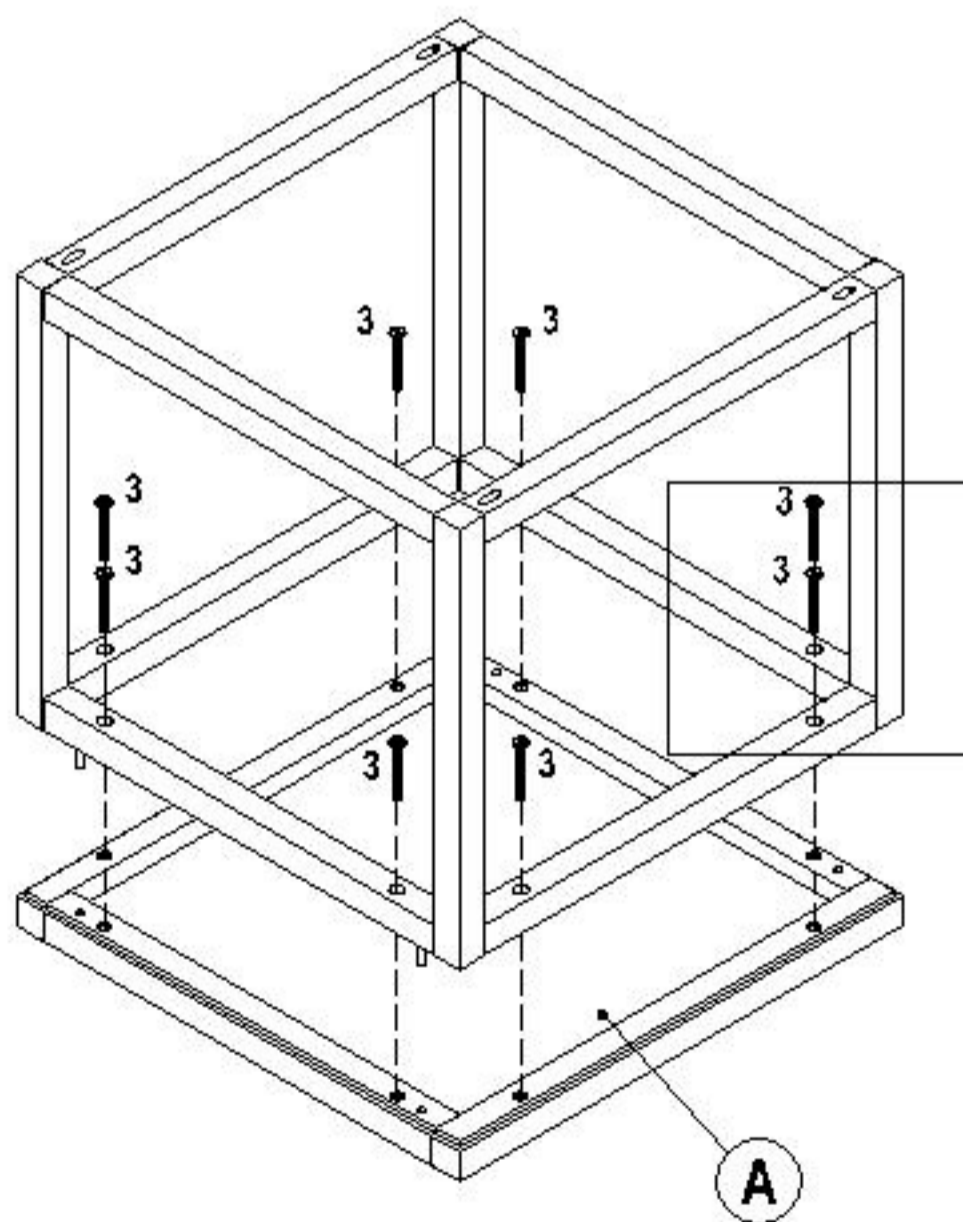

2

- (i) Carefully place the **TABLE TOP (A)** on a flat safe surface.
NOTE : Please find a suitable surface to avoid damaging the parts.
- (ii) Attach the assembled unit to **TABLE TOP (A)** using guiding dowels.
- (iii) Insert JCBC Screw (3) into correct hole position at **SIDE PANEL (B)** & **TOP RAIL (C)**, fully tighten the screw using 4mm Hex Wrench (4).